

**SERVICE BULLETIN**  
**INSTALLATION / USE OF GOVERNORS**  
**FOR ROTAX® ENGINE TYPE 912/914**  
**SB-912-052 UL R1**  
**SB-914-035 UL R1**

**OPTIONAL**

**Repeating symbols:**

Please, pay attention to the following symbols throughout this document emphasizing particular information.

- ▲ **WARNING:** Identifies an instruction, which if not followed, may cause serious injury or even death.
- **CAUTION:** Denotes an instruction which if not followed, may severely damage the engine or could lead to suspension of warranty.
- ◆ **NOTE:** Information useful for better handling.

**1) Planning information**

**1.1) Engines affected**

All versions of the engine type:

- 914 UL3
- 912 UL3
- 912 ULS3
- 912 ULSFR3
- V912 configuration 3
- V914 configuration 3

if they should get equipped with the governor. In case of doubt contact your aircraft manufacturer.

For complete instructions and compliance to this Service Bulletin refer to Service Bulletin SB-912-052 and SB-914-035, latest edition section 1.2 onward.

- ◆ **NOTE:** Section 1.6) Approval: Is not required for engines of the type UL (series).  
Section 3) Accomplishment: In addition: persons with adequate type-specific training.

# SERVICE BULLETIN

## INSTALLATION / USE OF GOVERNORS

### FOR ROTAX® ENGINE TYPE 912/914

#### SB-912-052 R1

#### SB-914-035 R1

## OPTIONAL

### Repeating symbols:

Please, pay attention to the following symbols throughout this document emphasizing particular information.

- ▲ **WARNING:** Identifies an instruction, which if not followed, may cause serious injury or even death.
- **CAUTION:** Denotes an instruction which if not followed, may severely damage the engine or could lead to suspension of warranty.
- ◆ **NOTE:** Information useful for better handling.

### 1) Planning information

#### 1.1) Engines affected

All versions of the engine type:

- 912 A3
- 912 F3
- 912 S3
- 914 F3

if they should get equipped with the governor. In case of doubt contact your aircraft manufacturer.

#### 1.2) Concurrent ASB/SB/SI and SL

- SI-912-018, "Purging of lubrication system" current issue.
- SI-914-020, "Purging of lubrication system" current issue.

#### 1.3) Reason

Replace / Retrofit under selection of different governor type and manufacturer.

#### 1.4) Subject

Installation / Use of governors for ROTAX® engine type 912/914.

#### 1.5) Compliance

On customer request.

#### 1.6) Approval

The technical content is approved under the authority of DOA Nr. EASA.21J.048.

#### 1.7) Manpower

Estimated man-hours:

engine installed in the aircraft - - - manpower time will depend on installation and therefore no estimate is available from the engine manufacturer.

#### 1.8) Mass data

change of weight - - - none.  
moment of inertia - - - unaffected.

#### 1.9) Electrical load data

no change

#### 1.10) Software accomplishment summary

no change

c04116

## 1.11) References

In addition to this technical information refer to current issue of

- Operators Manual (OM)
- Illustrated Parts Catalog (IPC)
- Installation Manual (IM)
- Maintenance Manual (MM)

◆ NOTE: The status of Manuals can be determined by checking the table of amendments of the Manual. The 1<sup>st</sup> column of the table is the revision status. Compare this number to that listed on the ROTAX WebSite: [www.rotax-aircraft-engines.com](http://www.rotax-aircraft-engines.com). Updates and current revisions can be downloaded free of charge.

## 1.12) Other publications affected

The following Service Bulletins must be replaced as a consequence of this Service Bulletin and will become invalid therefore:

- SB-912-011, "Use of an adapted propeller governor on Rotax engine type 912 A3 and 912 F3" current issue.
- SB-912-024, "Installation of propeller governor McCauley DCFU290D17B/T1" current issue.
- SB-912-025, "Installation of propeller governor McCauley DCFU290D17B/T2" current issue.
- SB-914-001, "Use of an adapted propeller governor on engine type ROTAX 914 F3" current issue.
- SB-914-009, "Installation of propeller governor McCauley DCFU290D17B/T2" current issue.

## 1.13) Interchangeability of parts

not affected

## 2) Material Information

### 2.1) Material - cost and availability

Price and availability will be supplied on request by ROTAX<sup>®</sup> Authorized Distributors or their Service Centers.

### 2.2) Company support information

none

### 2.3) Material requirement per engine

For installation of the governor the following parts are requirement:

Fig.no.	New p/n	Qty/engine	Description	Old p/n	Application
3	840681	3	allen screw M8X40	-	governor Woodward
3	841591	1	allen screw M8X35	-	governor Woodward
3	945752	4	lock washer A8	-	governor Woodward
3	931372	1	gasket	-	governor
3	840681	2	allen screw M8X40	-	governor McCauley
3	841591	1	allen screw M8X35	-	governor McCauley
3	940301	1	stud M8 X 37	-	governor McCauley
3	242206	1	hex. nut M8	-	governor McCauley
3	945752	4	lock washer A8	-	governor McCauley
3	931372	1	gasket	-	governor
3	840711	4	stud M8X21/20	-	governor Jihostroj
3	242206	4	hex. nut M8	-	governor Jihostroj
3	945752	4	lock washer A8	-	governor Jihostroj
3	931372	1	gasket	-	governor
3	840711	4	stud M8X21/20	-	governor MT-Propeller
3	242206	4	hex. nut M8	-	governor MT-Propeller
3	945752	4	lock washer A8	-	governor MT-Propeller
3	931372	1	gasket	-	governor

#### 2.4) Material requirement per spare part

none

#### 2.5) Rework of parts

none

#### 2.6) Special tooling/lubricant-/adhesives-/sealing compound - Price and availability

Price and availability will be supplied on request by ROTAX<sup>®</sup> Authorized Distributors or their Service Centers.  
parts requirement:

Fig.no.	p/n	Qty/engine	Description	Old p/n	Application
	899785	as required	Loctite 221 violet	-	stud

### 3) Accomplishment / Instructions

#### Accomplishment

All the measures must be taken and confirmed by the following persons or facilities:

- ROTAX<sup>®</sup> -Airworthiness representative
- ROTAX<sup>®</sup> -Distributors or their Service Centers
- Persons approved by the respective Aviation Authority

▲ **WARNING:** Proceed with this work only in a non-smoking area and not close to sparks or open flames. Switch off ignition and secure engine against unintentional operation. Secure aircraft against unauthorized operation. Disconnect negative terminal of aircraft battery.

▲ **WARNING:** Risk of scalds and burns! Allow engine to cool sufficiently and use appropriate safety gear while performing work.

▲ **WARNING:** Should removal of a locking device (e.g. lock tabs, self-locking fasteners, etc.) be required when undergoing disassembly/assembly, always replace with a new one.

◆ **NOTE:** All work has to be performed in accordance with the relevant Maintenance Manual.

#### 3.1) Overview of approved governors

manufacturer	type designation	propeller gear ratio
Woodward	A210786 <sup>1)</sup>	2,27 /2,43 <sup>3)</sup>
Woodward	A210790 <sup>2)</sup>	2,27 /2,43 <sup>3)</sup>
McCauley	DC290D17B/T1 <sup>1)</sup>	2,27
McCauley	DCFU290D17B/T1 <sup>2)</sup>	2,27
McCauley	DC290D17B/T2 <sup>1)</sup>	2,43
McCauley	DCFU290D17B/T2 <sup>2)</sup>	2,43
Jihostroj	P-110-029/A <sup>1)</sup>	2,27
Jihostroj	P-110-030/A <sup>1)</sup>	2,43
MT-Propeller	P-850-34 <sup>1)</sup>	2,27
MT-Propeller	P-871-34 <sup>4)</sup>	2,27
MT-Propeller	P-875-34 <sup>2)</sup>	2,27
MT-Propeller	P-850-12 <sup>1)</sup>	2,43
MT-Propeller	P-871-12 <sup>4)</sup>	2,43
MT-Propeller	P-875-12 <sup>2)</sup>	2,43

<sup>1)</sup> without hydraulic controlled feathering pitch propeller; increase in pressure causes propeller pitch increase

<sup>2)</sup> with hydraulic controlled feathering pitch propeller; increase in pressure causes propeller pitch reduction

<sup>3)</sup> adjusted for reduction ratio  $i=2,43$  by ROTAX<sup>®</sup> or authorized facilities. This service is not available from ROTAX<sup>®</sup> anymore.

<sup>4)</sup> with hydraulic controlled feathering pitch propeller without accumulator connection; increase in pressure causes propeller pitch reduction.

### 3.2) Attachment flange

(see fig. 1)

attachment flange: AND20010  
governor drive: internal tothing 20/40 SMS 1834 NA 14x1.27x30x12  
reduction ratio: 0,58 of the engine speed at gearbox with  $i= 2,27$   
0,54 of the engine speed at gearbox with  $i= 2,43$   
direction of rotation  
of governor drive: clockwise rotation seen on the attachment flange

### 3.3) Removal of old governor

- Remove governor or cover plate (15) according to the current Maintenance Manual

### 3.4) Installation of the governor

#### 3.4.1) Installation of the woodward governor

(see fig. 3)

- Install the Woodward governor (1) complete with a new gasket (2) with 3 allen screws M8x40 (3), one allen screw M8x35 (4) and lock washers (5). Tighten fasteners to 22 Nm (195 in lb.). Make sure that the tothing of the governor drive is engaged properly.

◆ NOTE: Fit the allen screw M8x35 (4) in lower left side location! Otherwise the crankcase housing will be damaged!

#### 3.4.2) Installation of the McCauley governor

(see fig. 3)

- Fit the stud M8x37/15 (6) with Loctite 221 as required and by use of a suitable tool into governor flange and tighten to 5 Nm (44 in lb.). Short thread goes into flange, long thread into governor.

◆ NOTE: Fit the stud in top right side location as viewed from MAG side of engine with the shorter end (14 mm) (0.55 in.) in the governor flange (see fig. 3)!

- Install the McCauley governor (7) complete with a new gasket (8) with 2 allen screws M8x40 (3), one allen screw M8x35 (4) and lock washers (5) and hex. nut M8 A/F(9). with lockwashers (5). Tighten fasteners to 22 Nm (195 in lb.). Make sure that the tothing of the governor drive is engaged properly.

◆ NOTE: Fit the allen screw M8x35 (4) in lower left side location! Otherwise the crankcase housing will be damaged!

#### 3.4.3) Installation of the Jihostroj governor

(see fig. 3)

- Fit the stud M8x21/20 (10) with Loctite 221 as required and by use of a suitable tool into governor flange and tighten to 8 Nm (70 in lb.). Short thread goes into flange, long thread into governor.
- Install the Jihostroj governor (11) complete with a new gasket (12) hex. nut M8 A/F(9) and lock washers (5). Tighten fasteners to 22 Nm (195 in lb.). Make sure that the tothing of the governor drive is engaged properly.

#### 3.4.4) Installation of the MT-Propeller governor

(see fig. 3)

- Fit the stud M8x21/20 (10) on short thread with Loctite 221 as required and by use of a suitable tool into governor flange and tighten to 8 Nm (70 in lb.).
- Install the MT-Propeller governor (13) complete with a new gasket (14) hex. nut M8 A/F(9) and lock washers (5). Tighten fasteners to 22 Nm (195 in lb.). Make sure that the tothing of the governor drive is engaged properly.

#### 3.4.5) General installation requirements

(see fig. 2)

- For the actuation of the governor control lever (16) a proper cable support has to be installed by the aircraft manufacturer. This is necessary as the cable supports cast into the intake manifold is foreseen for the Woodward and McCauley governors, which are longer in length.

■ CAUTION: The actuation of the MT-Propeller governor compared to the other governor type has an opposite actuation direction. For the actuation of the governor control lever a proper cable support has to be installed by the aircraft manufacturer.

- Refer to the information of the governor and aircraft manufacturer on installation, function, operation and maintenance of the governor.
- Restore aircraft to original operating configuration.
- Vent the lubrication system according to the current Maintenance Manual and Service Instruction SI-912-018/SI-914-020, current issue (if the lubrication system was opened or drained during maintenance work).
- Connect negative terminal of aircraft battery.

### 3.5) Check of governor

Operational test of the governor as per specification of the Flight Manual and manufacturer.

### 3.6) Test run

Conduct test run including ignition check, leakage test and oil pressure check in accordance with the relevant Maintenance Manual.

### 3.7) Summary

These instructions (section 3) have to be conducted in accordance with compliance in section 1.5.

Confirm the implementation of the specified Service Bulletin in the Engine Log.

Approval of translation to best knowledge and judgement - in any case the original text in German language and the metric units (SI-system) are authoritative.

#### 4) Appendix

the following drawings should convey additional information:

A.....attachment points  
of the governor

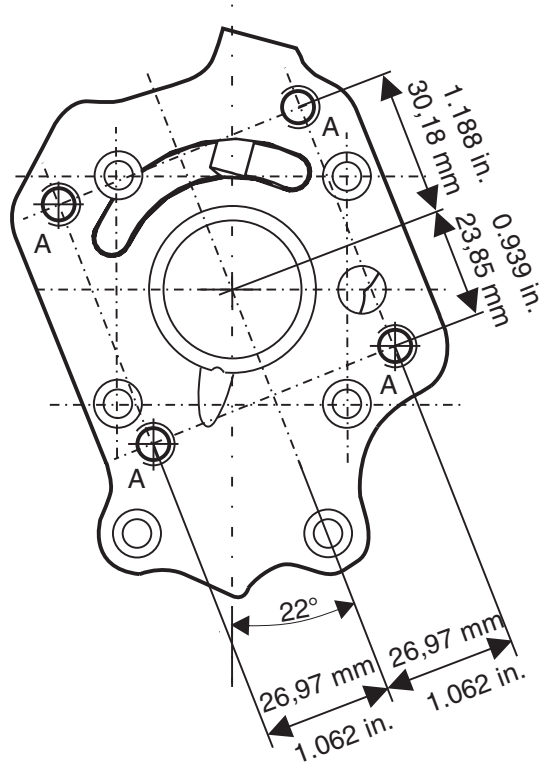

08179  
fig. 1

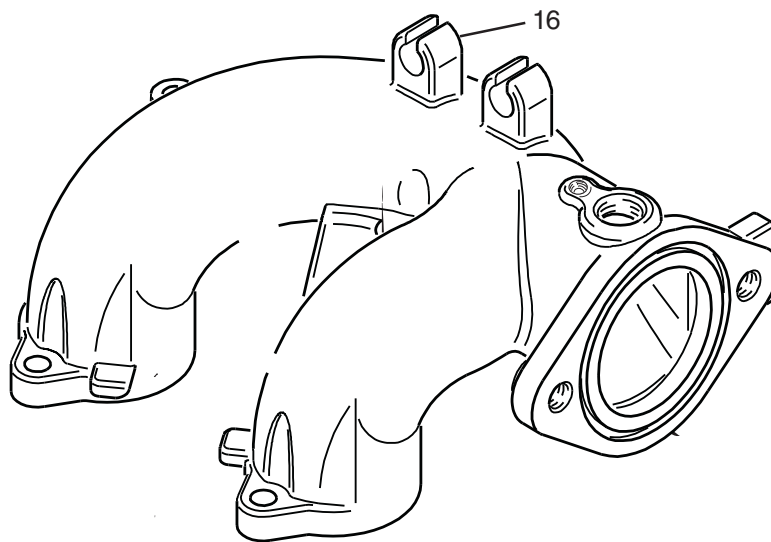

08178  
fig. 2

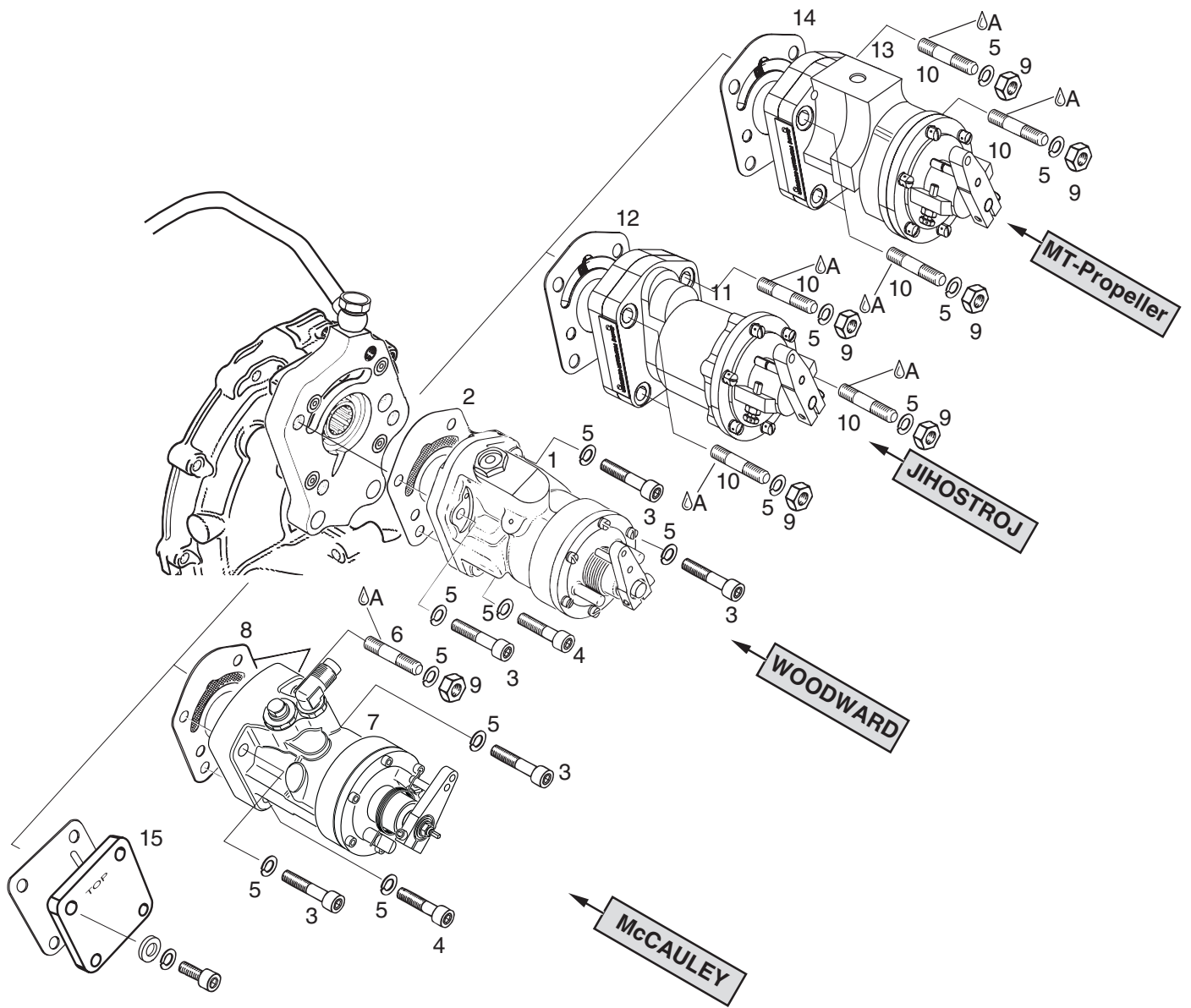

08177  
fig. 3

∆A: LOCTITE 221

- ◆ NOTE: The illustrations in this document show the typical construction. They may not represent full detail or the exact shape of the parts which have the same or similar function. Exploded views are **no technical** drawings and are for reference only. For specific detail, refer to the current documents of the respective engine type.